



# Air Conditioning

# SUBMITTAL DATA SHEET

## MODEL: Cooling Only 60Hz -RXQ8TATL

### PROJECT NAME:

Location:	Approval:
Engineer:	Date:
Submitted to:	Construction:
Submitted by:	Unit #:
Reference:	Drawing #:

### FEATURES AND BENEFITS

Large Capacity unit. A single Cooling Only VRV IV outdoor unit (RXQ-TA) capacity ranges from 6 HP to 20 HP in increments of 2 HP, and the capacity of a triple outdoor unit system is up to 60 HP.

Highly-integrated Daikin VRV IV system (RXQ-TA) offers compact outdoor units to achieve maximum utilization of space in modern buildings. Can be transported easily by elevator.

VRV IV outdoor unit (RXQ-TA) has been achieved high external static pressure up to 78.4 Pa\*, ensuring the efficient heat dissipation and stable operation of equipment in either hierarchical or intensive arrangement.

Higher Coefficient of Performance (COP) delivers highly efficient performance, contributing to high energy savings. Savings are specially improved during low load operation due to Daikin's own unique VRT technology automatically adjusts refrigerant temperature to individual building and climate requirement, thus further improving annual energy efficiency and maintaining comfort.

High-efficiency DC Inverter Scroll Compressor with high-pressure and low-pressure chambers, which can dramatically enhance compression efficiency by making full use of the compression chamber.

Integrated 4-side heat exchanger ensures the high efficiency and energy saving of Daikin VRV IV system. Effective heat exchange area of a VRV IV heat exchanger module is over 200 m<sup>2</sup>, 2.7 times larger than that of VRV III system.

State-of-the-Art energy Saving Technology for VRV system, during cooling, the refrigerant evaporating temperature (Te) is raised to minimize the difference with the condensing temperature. Compressors work less, and this reduces power consumption.

New generation intelligent control main PC board with SMT packaging that improves the anti-clutter performance and protects your computer boards from the adverse effect of sandy and humid weather.

Simplified commissioning and after-sales service

Lower operation sound, double backup operation functions, more accurate test operation and stable system, easy maintenance.

### EXTERNAL APPEARANCE

# VRV IV



**INVERTER** **R-410A**



### SPECIFICATIONS

Model Name		<b>RXQ8TATL</b>	
Power Supply		3 phase, 220 V, 60 Hz	
*1 Cooling Capacity	kcal/h	19,300	
	Btu/h	76,400	
	kW	22.4	
Casing Color		Ivory white (5Y7.5/1)	
Dimensions: (AlxAh×Prof)		mm	1,657×930×765
Heat Exchanger		Cross fin coil	
Compressor	Type	Hermetically sealed scroll type	
	Motor Output× Number of Units	kW	3.4×1
	Starting Method		Soft start
Fan	Type	Propeller fan	
	Motor Output	kW	0.65×1
	Airflow Rate	m <sup>3</sup> /min	157
	Drive		Direct drive
Connecting Pipes	Liquid Pipe	mm	φ9.5 C1220T (Brazing connection)
	Gas Pipe	mm	φ19.1 C1220T (Brazing connection)
Mass		kg	185
*2 Sound Pressure Level		dB(A)	56
Safety Devices		High pressure switch, Fan driver overload protector, Overcurrent relay, Inverter overload protector	
Capacity Control		%	20-100
Refrigerant	Refrigerant Name		R410A
	Charge	kg	5.9
	Control		Electronic expansion valve
Refrigerator Oil		Refer to the nameplate of compressor	
Standard Accessories		Installation manual, Operation manual, Connection pipes, Clamps	
Drawing No.	Specifications		C: 3D103579B
	Sound level		C: 4D103809
<p>Notes:</p> <p>*1. Indoor temp.: 27°CDB, 19°CWB / outdoor temp.: 35°CDB / Equivalent piping length: 7.5m, level difference: 0m.</p> <p>*2. Anechoic chamber conversion value, measured at a point 1 m in front of the unit at a height of 1.5m.</p> <p>*3. During actual operation, these values are normally somewhat higher as a result of ambient conditions.</p> <p>4. Refer to Capacity Tables for the power input (PI) (Compressor + Outdoor fan motor).</p>			

### DIMENSIONS

Unit: mm

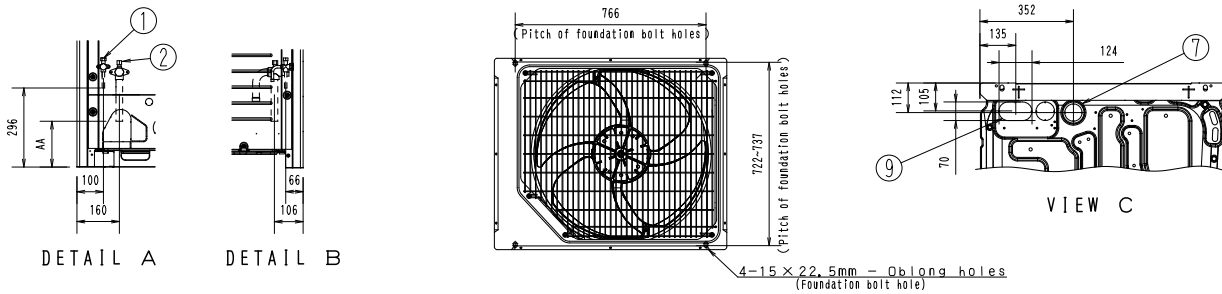

DETAIL A

DETAIL B

VIEW C

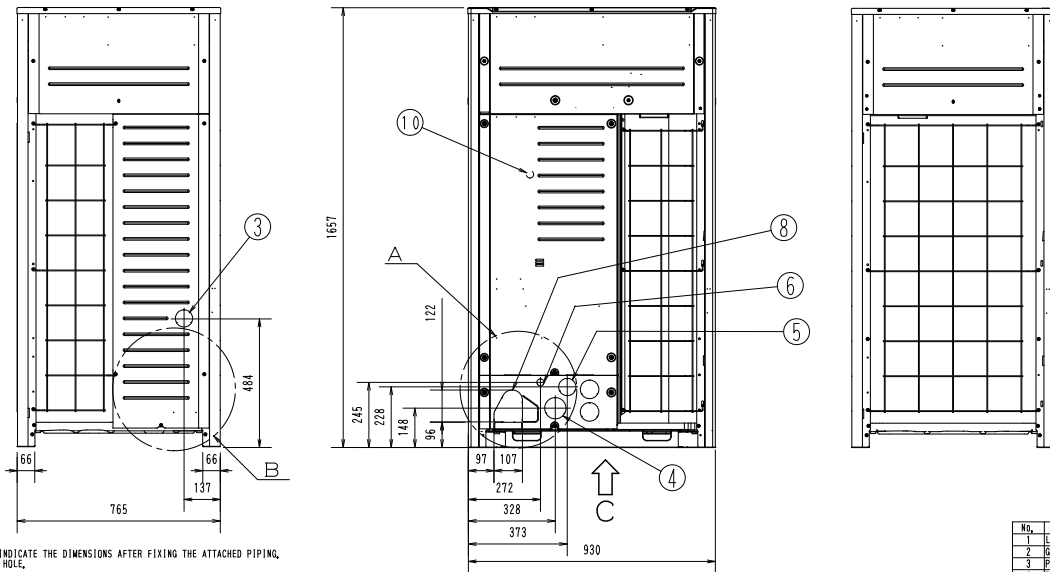

NOTES:  
 1. DETAIL A AND DETAIL B INDICATE THE DIMENSIONS AFTER FIXING THE ATTACHED PIPING.  
 2. ITEMS 3 TO 9 KNOCK OUT HOLE.  
 GAS PIPE:  
 Φ13.1 BRAZING CONNECTION: RX(Y)06 • 8T  
 Φ22.2 BRAZING CONNECTION: RX(Y)010T  
 Φ26.6 BRAZING CONNECTION: RX(Y)012T  
 LIQUID:  
 Φ9.5 BRAZING CONNECTION: RX(Y)06 • 8 • 10T  
 Φ12.7 BRAZING CONNECTION: RX(Y)012T

MODEL	AA
RX06 • 8 • 10TA	167
RXQ12TA	171

No.	Parts name	Remarks
1	Liquid pipe connection part	See note 3.
2	Gas pipe connection part	See note 3.
3	Power cord routing hole (side)	Φ65
4	Power cord routing hole (front)	Φ80
5	Power cord routing hole (front)	Φ65
6	Power cord routing hole (front)	Φ77
7	Power cord routing hole (bottom)	Φ65
8	Pipe routing hole (front)	
9	Pipe routing hole (bottom)	
10	Grounding terminal	Inside of switch box (M8)

C: 3D084511E