

PROJECT NAME:

Location:	Approval:
Engineer:	Date:
Submitted to:	Construction:
Submitted by:	Unit #:
Reference:	Drawing #:

FEATURES AND BENEFITS

This VAM series provides higher enthalpy efficiency, due to the greatly enhanced performance of the thin film element. Furthermore, improved external static pressure offers more flexibility for installation. Along with these three outstanding improvements, the nighttime free cooling operation contributes to energy conservation and more comfortable space.

Air conditioning load reduced by approximately 31%! This unit recovers heat energy lost through ventilation and curbs room temperature changes caused by ventilation, thereby conserving energy and reducing the load on the air conditioning system.

Enthalpy efficiency drastically improved by employing thin film element! Due to the thinner film... Decreases the moisture resistance of the partition sheets drastically. Realises more space for extra layers in the element, resulting in increased effective area that supply and exhaust air can be exposed to.

Auto-ventilation Mode Changeover Switching, automatically switches the ventilation mode (Total Heat Exchange Mode/Bypass Mode) according to the operating status of the air conditioner.

Pre-cool, Pre-heat Control reduces air conditioning load by not running the Heat Reclaim Ventilator while air is still clean soon after the air conditioner is turned ON.

Night time free cooling operation an energy-conserving function that works at night when air conditioners are off. By ventilating rooms containing office equipment that raises the room temperature, night time free cooling operation reduces the cooling load when air conditioners are turned on in the morning. It also alleviates feelings of discomfort in the morning caused by heat accumulated during the night.

EXTERNAL APPEARANCE



SPECIFICATIONS

MODEL				VAM250GJVE			
Power Supply				1-phase, 220-240 V/220 V, 50 Hz/60 Hz			
Temp. Exchange Efficiency		Ultra-High	%	75			
		High		75			
		Low		79			
Enthalpy Exchange Efficiency		For Heating		Ultra-High	71		
				High	71		
				Low	74		
		For Cooling		Ultra-High	63		
				High	63		
				Low	66		
Power Consumption		Heat Exchange Mode		Ultra-High	137		
				High	120		
				Low	60		
		Bypass Mode		Ultra-High	137		
				High	120		
				Low	60		
Sound Level		Heat Exchange Mode		Ultra-High	27-29		
				High	26-27.5		
				Low	21-22		
		Bypass Mode		Ultra-High	28.5-30.5		
				High	27.5-29		
				Low	22.5-23		
Casing				Galvanised steel plate			
Insulation Material				Self-extinguishable polyurethane foam			
Dimensions (HXWXD)			mm	278X810X551			
Machine Weigh			kg	24			
Heat Exchange System				Air to air cross flow total heat (Sensible heat+ latent heat) exchange			
Heat Exchange Element Material				Specially processed non-flammable paper			
Air Filter				Multidirectional fibrous fleeces			
Fan		Type		Sirocco fan			
		Airflow Rate		Ultra-High	250		
				High	250		
				Low	155		
		External Static Pressure		Ultra-High	70		
				High	54		
				Low	24		
		Motor Output		kW		0.030X2	

SPECIFICATIONS

MODEL: Heat Reclaim Ventilator VAM250GJVE

1. Sound level is measured at 1.5 m below the centre of the body.
2. Airflow rate can be changed over to Low mode or High mode.
3. Sound level is measured in an anechoic chamber.
4. Sound level generally becomes greater than this value depending on the operating conditions, reflected sound, and peripheral noise.
5. The sound level at the air discharge port is about 8 dB(A) higher than the unit's sound level.
6. The specifications, designs and information given here are subject to change without notice.
7. Temperature Exchange Efficiency is the mean value between cooling and heating.
8. Efficiency is measured under the following conditions: Ratio of rated external static pressure has been maintained as follows; outdoor side to indoor side = 7 to 1.
9. In conformance with JIS standards (JIS B 8628), operating sound level is based on the value when one unit is operated, with the value converted for an anechoic chamber. This is transmission sound from the main unit, and does not include sound from the discharge grille. Thus it is normal for the sound to be louder than the indicated value when the unit is actually installed.
10. Sound level from the discharge port causes the value to be approximately 8 dB(A) (models with the airflow rate of less than 150 to 500 m³/h) to approximately 11 dB(A) (models with the airflow rate of 650 m³/h or more) greater than the indicated value. Furthermore, fan rotation and noise from the discharge grille may increase depending on the on-site duct resistance conditions. Please consider noise countermeasures when installing the unit. With large models in particular (1500 and 2000 m³/h models), if the supply air (SA) grille is installed near the main unit, the noise of the main unit may be heard from the discharge grille via the duct, and this will result in a marked increase in noise. In such cases, if peripheral effects are included (such as reverberation of the floor and walls, combination with other equipment, and background noise), sound level may be as much as 15 dB(A) higher than the indicated value.
11. When installing a large model, please provide as much separation as possible between the main unit and the discharge grille. If the equipment and discharge grille are near each other, please consider countermeasures such as the following:
 - Use a sound-muffling box, flexible duct and sound-muffling air supply/discharge grilles
 - Decentralised installation of discharge grilles
12. When installing in a location with particularly low background noise such as a classroom, please consider the following measures to avoid transmission sound from the main unit:
 - Use of ceiling materials with high sound insulating properties (high transmission loss)
 - Methods of blocking sound transmission, for example, by adding sound insulating materials around the bottom of the sound source. Alternatively, consider supplementary methods such as installing the equipment in a different location (corridor, etc.)

DIMENSIONS

VAM250GJVE

Unit (mm)

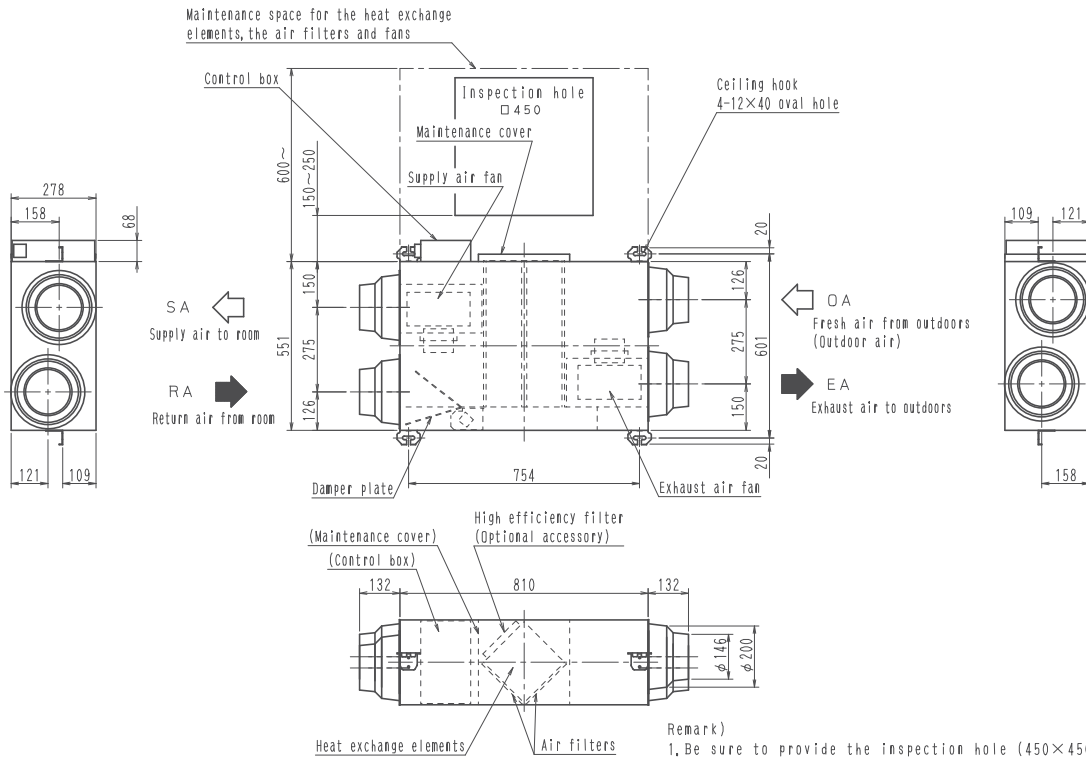

Remark)

1. Be sure to provide the inspection hole (450×450 mm) to inspect the air filters, the exchange elements and fans.
2. It is possible to install the high efficiency filter on the SA face side of heat exchange element.

3D051175